

FRONT ELEVATION

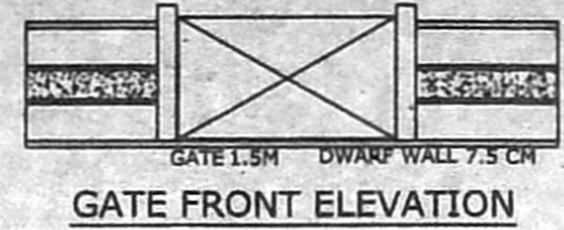

GATE FRONT ELEVATION

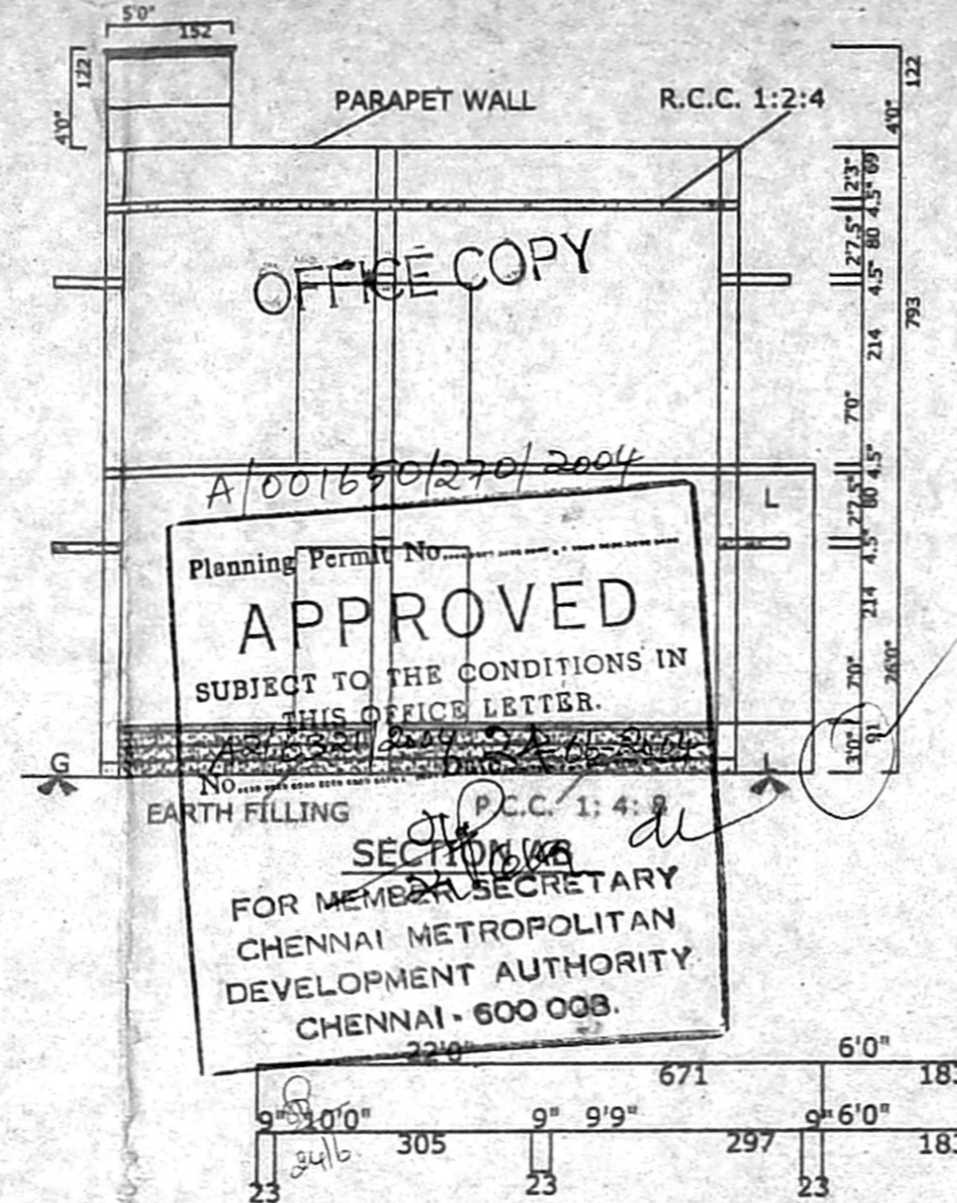
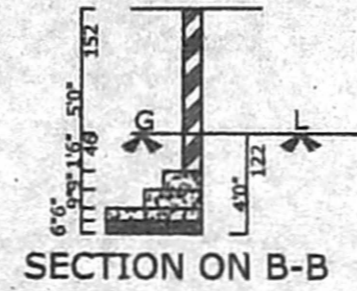

SECTION ON B-B

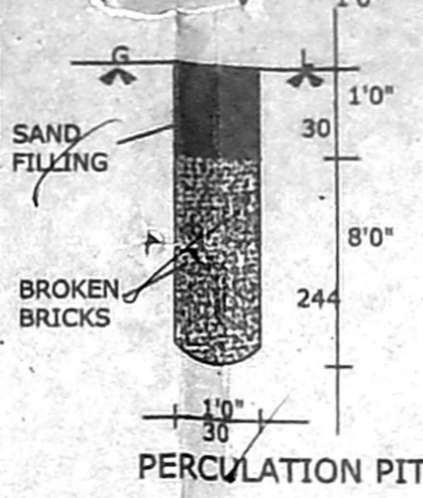

PERCOLATION PIT

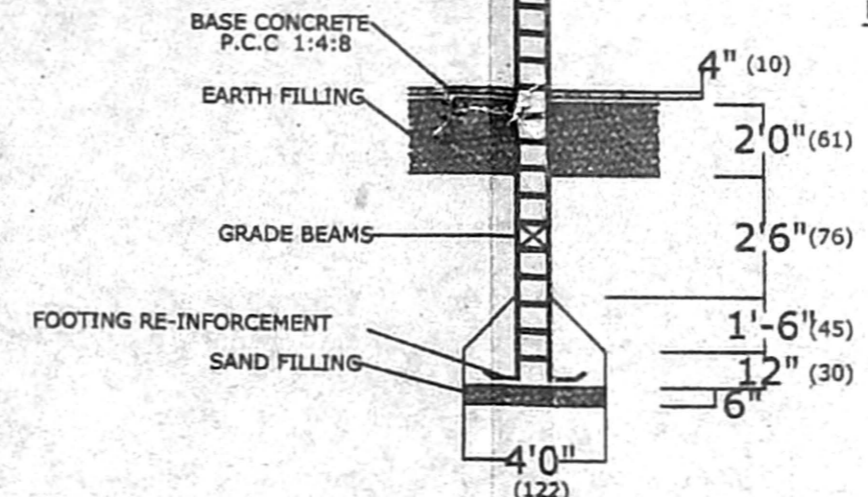

DETAILS OF COLUMN FOOTINGS

KEY PLAN NOT TO SCALE

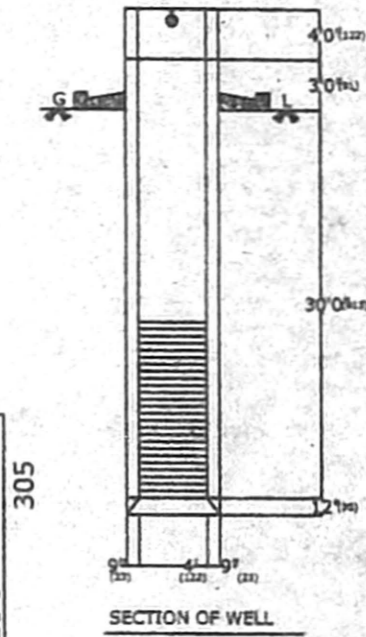

SECTION OF WELL

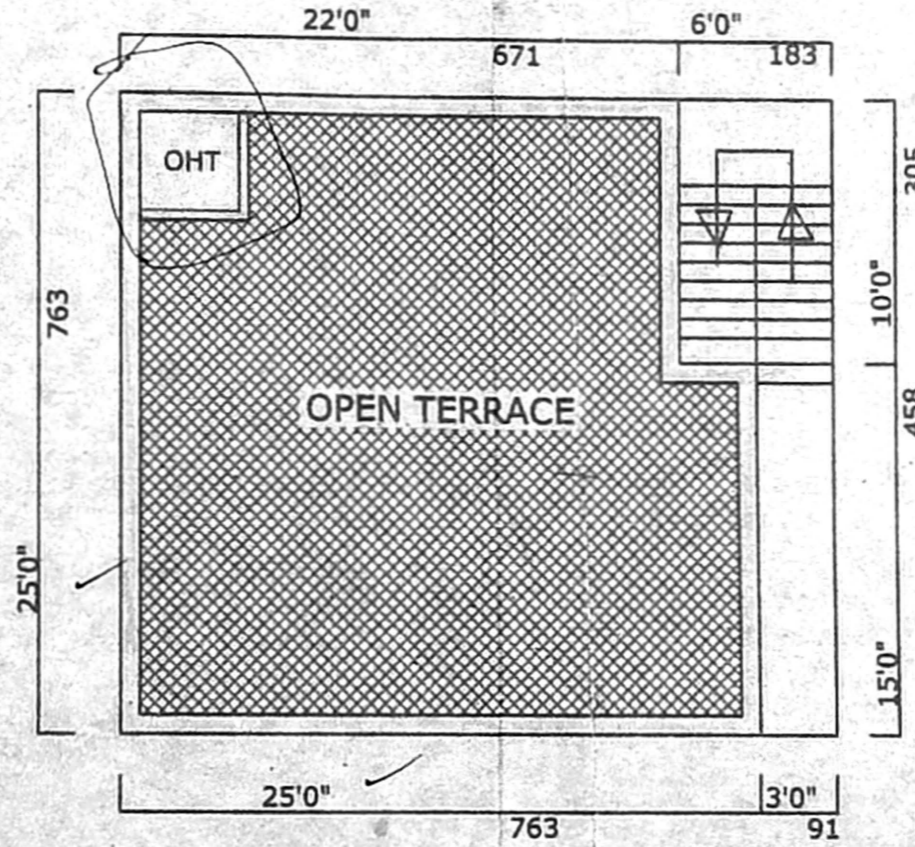

TERRACE PLAN

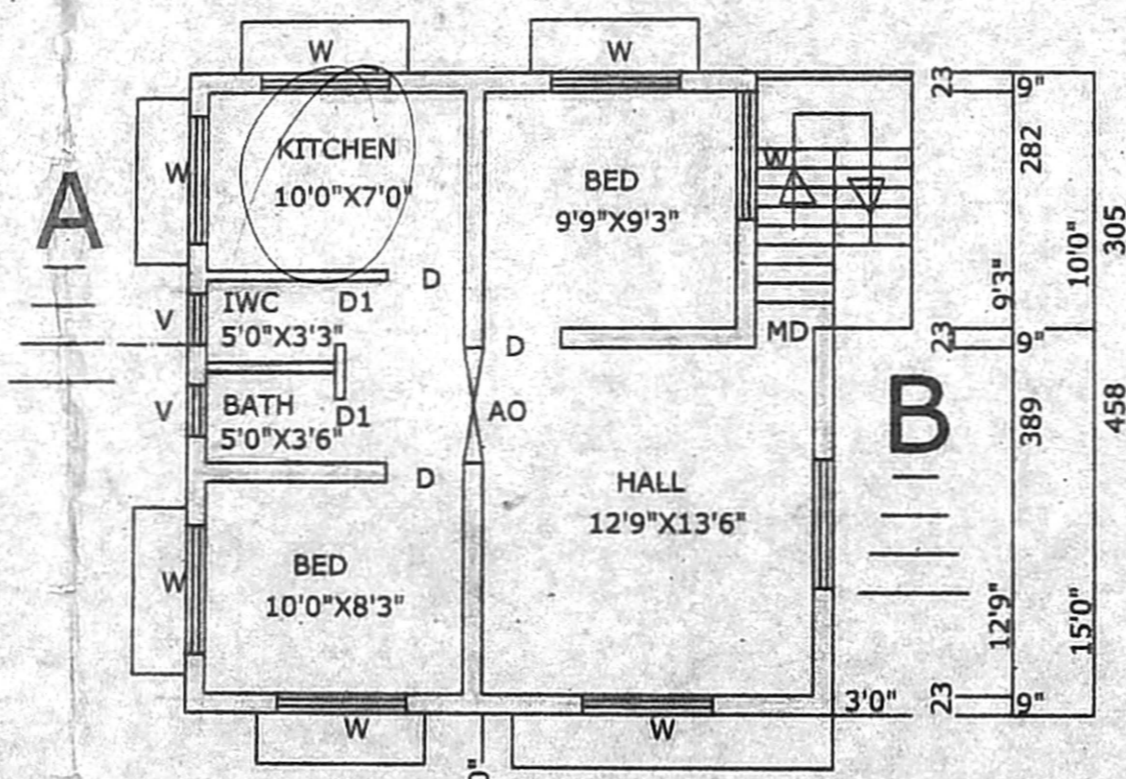

F.FLOOR PLAN

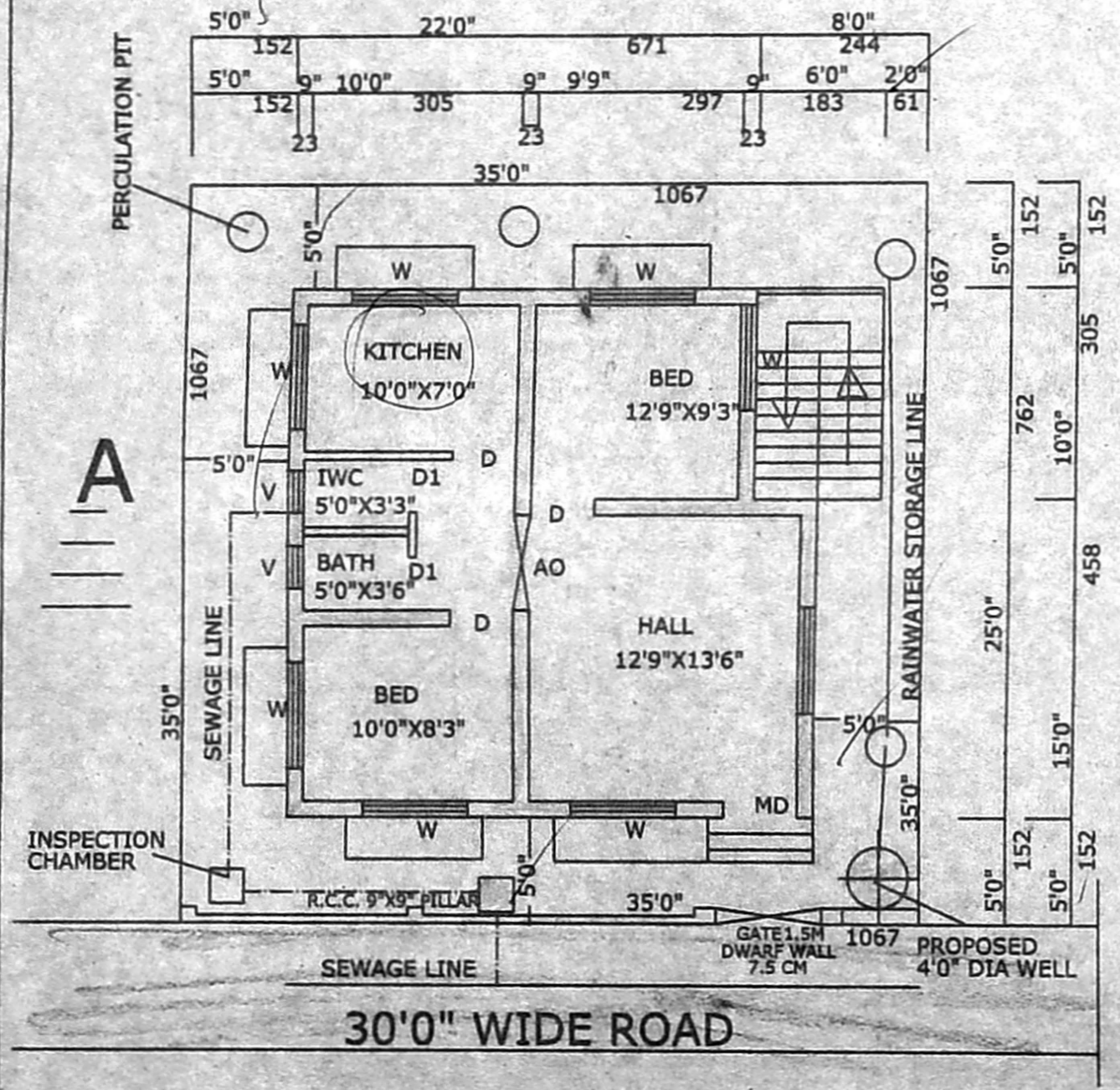

SITE PLAN CUM G.FLOOR PLAN

ALL DIMENSIONS ARE CM & FEET

ONLY OFFICE USE

SPECIFICATIONS

1. P.C.C 1 : 4 : 8, USING 40mm HBG JELLY FOR FOUNDATION BED CONCRET.
2. R.C.C WORK 1 : 2 : 4, USING 20mm HBG (STON) JELLY. A CHANNEL
3. BRICK WORK IN CM 1 : 5 FOR FOUNDATION. P.C.C. 1:4:8
4. 12mm TK CEMENT PLASTERS CM 1:4.
5. ALL WOOD WORKS ARE IN SEASONED.

JOINERY DETAILS

- MD - MAIN DOOR - 3'-6" x 7'-0" (106 X 214)
- A.P. DOOR - 3'-0" x 7'-0" (91x214)
- D1 - DOOR - 2'-9" x 7'-0" (84x214)
- W - WINDOW - 5'-0" x 4'-6" (152x137)
- W1 - WINDOW - 4'-0" x 4'-6" (122x137)
- W2 - WINDOW - 3'-0" x 4'-0" (91x122)
- V - VENTILATOR - 2'-0" x 1'-6" (61x46)

AREA DETAILS

- AREA OF THE LAND = 1225 Sq.Ft. 114M2
- AREA OF G.FLOOR = 595 SqFt (55 M2)
- AREA OF F.FLOOR = 595 SqFt (55 M2)
- AREA OF OHT = 25 SqFt
- PLOT COVERAGE = 49%
- FLOOR SPACE INDEX = 0.98

COLOR INDEX

PROPOSED SHOWN	<input type="checkbox"/>
EXISTING SHOWN	<input type="checkbox"/>
ROAD SHOWN	<input type="checkbox"/>
BOUNDARY SHOWN	<input type="checkbox"/>

G. Hemachander, D.C.E. AMISE, MICI, MISET
Civil Engineer & Licensed Surveyor,
Ambattur, Avadi, & Corporation of Chennai,
Class. II - 408

LICENCED SURVEYOR

No. 214, ...

[Signature]

SIGNATURE OF OWNER

OWNER NAME: MR. M.P. SUNDARA VADIVEL
THE PLAN SHOWS THE PROPOSED CONSTRUCTION OF A HOUSE BUILDING
IN II MAIN ROAD, SENTHIL NAGAR, AT OLD S.NO. 32/3, NEW FIELD
S.NO. 127/1, AS PER PATTI KOLATHUR VILLAGE, PERAMBUR TALUK,
CHENNAI CORPORATION LIMIT, CHENNAI DISTRICT.
PLOT APPROVAL NO.L.P.T.M/D.T.D.P.NO.35/71,

MERIT CONSTRUCTIONS
No.5, GAJALAKSMI APARTMENTS,
ORAGADAM ROAD,
AMBATTUR,
CHENNAI - 600 053.
PHONE:- 2657 1153. CELL: 98411 14112